



TRI-STATE BUILDING SPECIALTIES
 1985 RUTGER UNIVERSITY BLVD
 LAKEWOOD, NJ 08701
 732-780-9756 PHONE
 888-567-2049 FAX

12' X 12' GABLE SUNROOM
 6" INSULATED FLOOR SYSTEM

MINIMUM N DESIGN LOADS:

DEAD LOADS:

- 1. ROOF: 2 PSF
- 2. WALLS: 5 PSF
- 3. FLOOR: 5 PSF

LIVE LOADS:

- 1. ROOF: 30 PSF
- 2. WALLS: 120 MPH - 3 SEC. WIND GUST
- 3. FLOOR: 40 PSF

DEFLECTION LIMITS:

- 1. ROOF: L/180
- 2. WALLS: L/175
- 3. FLOOR: L/240

SUNROOM SPECIFICATIONS

ROOM STYLEGABLE 8' TO 10'
 ROOM DIMENSIONS: 12' x 12'
 COLOR: WHITE
 HIGH PERFORMANCE MULTI COAT GLASS
 SLIDING WINDOWS TEMP SAFETY TEMPERED

TRI-STATE SUNROOMS MEET THE BELOW REQUIREMENTS:

- INTERNATIONAL RESIDENTIAL CODE 2009, NEW JERSEY EDITION - R308 - " GLAZING" REQUIRED TEMPERED SAFTY GLASS/ETCHED
- INTERNATIONAL RESIDENTIAL CODE 2009, NEW JERSEY EDITION - R301.2.1 MEETS THE MINIMUM 115MPH WIND SPEED FOR THE AREA
- INTERNATIONAL RESIDENTIAL CODE 2009, NEW JERSEY EDITION - R301.2.3 MEETS THE MINIMUM 30PSF SNOW LOAD
- MEETS THE NATIONAL ELECTIC 2011 EDITION

TRI-STATE BUILDING SPECIALTIES

1985 RUTGERS UNIVERSITY BLVD
 LAKEWOOD, NJ 08701

JAMES A. CLANCY

Professional Engineer & Land Surveyor NJ LIC# 33998
 Professional Planner NJ LIC# 04200

CLIENT: SAMPLE SUNROOM

JAMES A. CLANCY

CONSULTING ENGINEER
 601 ASBURY AVENUE
 NATIONAL PARK, NJ 08063

Fax: 856-853-7381
 Phone: 856-853-7306

ELEVATIONS

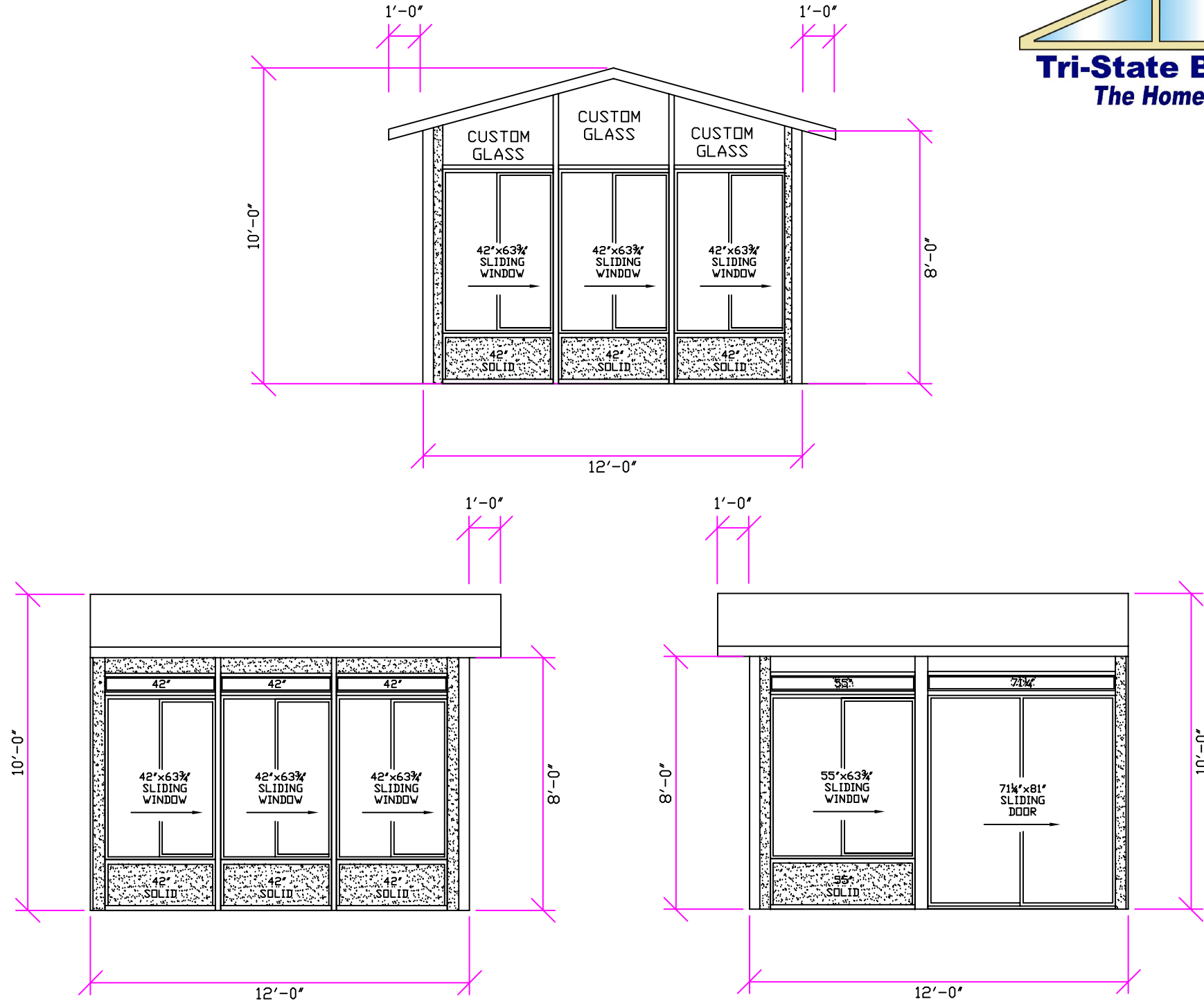

TRI-STATE BUILDING SPECIALTIES
1985 RUTGERS UNIVERSITY BLVD
LAKEWOOD, NJ 08701



CLIENT: SAMPLE SUNROOM

JAMES A. CLANCY

JAMES A. CLANCY
CONSULTING ENGINEER
601 ASBURY AVENUE
NATIONAL PARK, NJ 08063

Fax: 856-853-7381
Phone: 856-853-7306

Professional Engineer & Land Surveyor NJ LIC# 33998
Professional Planner NJ LIC# 04200

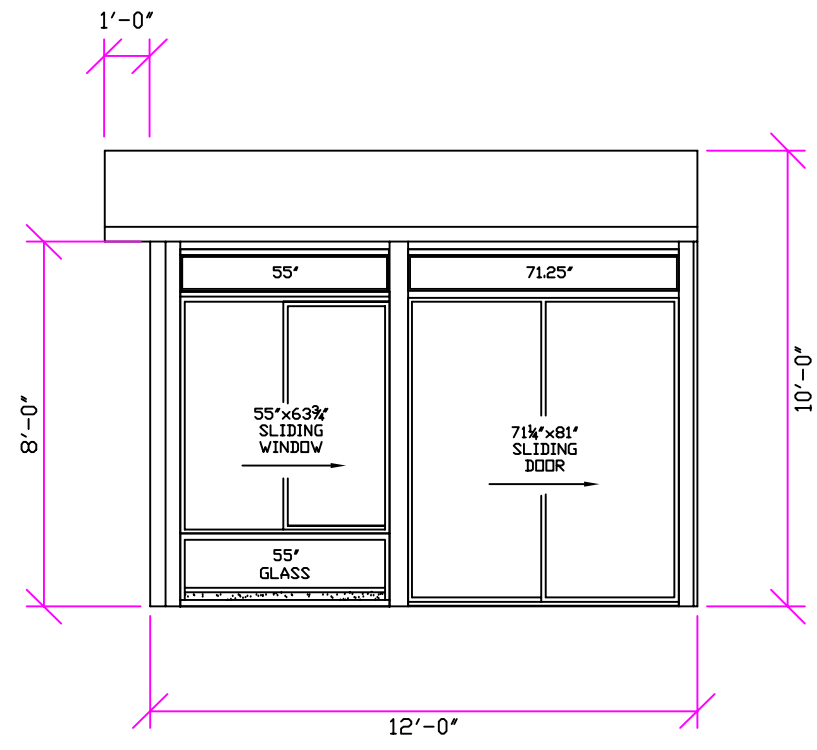
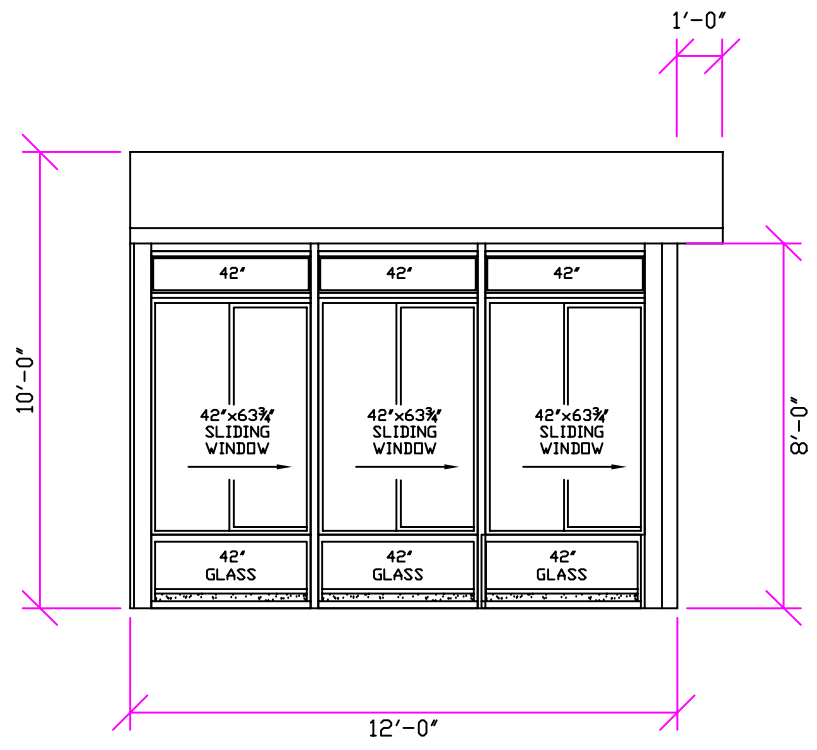
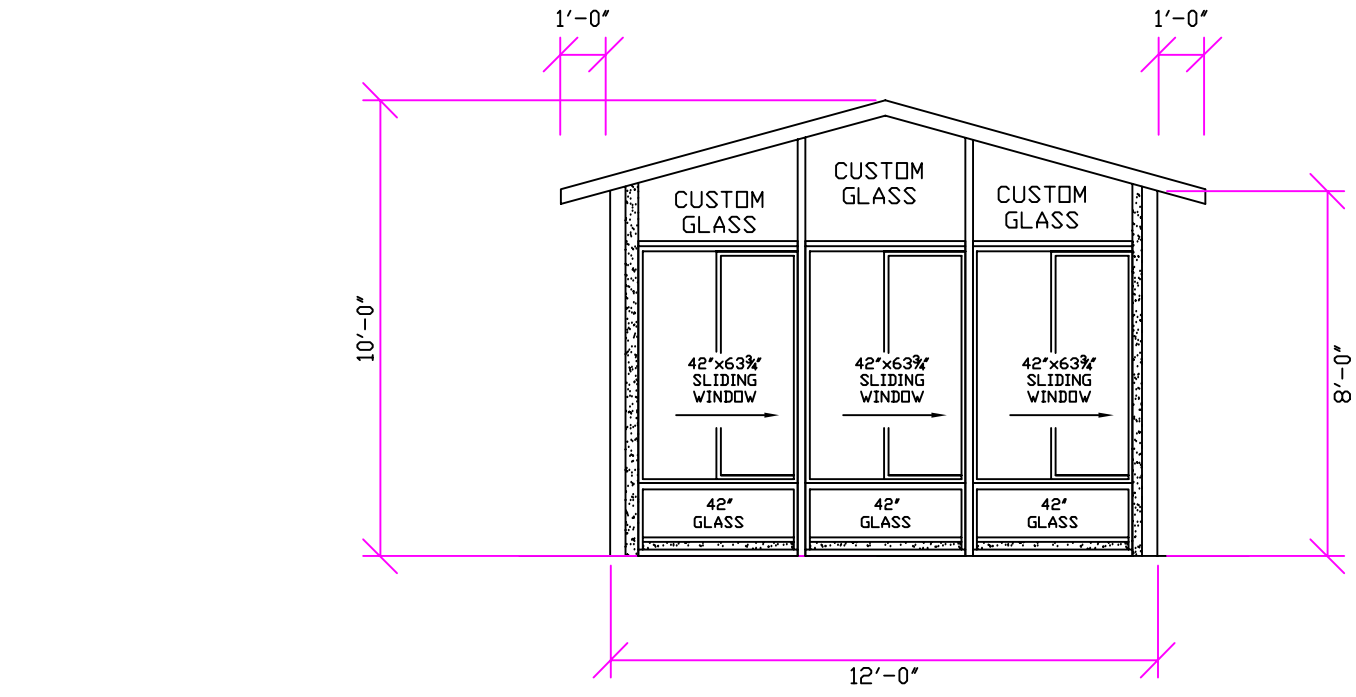

TRI-STATE BUILDING SPECIALTIES
1985 RUTGERS UNIVERSITY BLVD
LAKEWOOD, NJ 08701

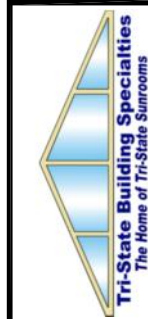

CLIENT: SAMPLE SUNROOM

JAMES A. CLANCY
CONSULTING ENGINEER
601 ASBURY AVENUE
NATIONAL PARK, NJ 08063

JAMES A. CLANCY

Fax: 856-853-7381
Phone: 856-853-7306

NJ LIC# 33998
NJ LIC# 04200

Professional Engineer & Land Surveyor
Professional Planner

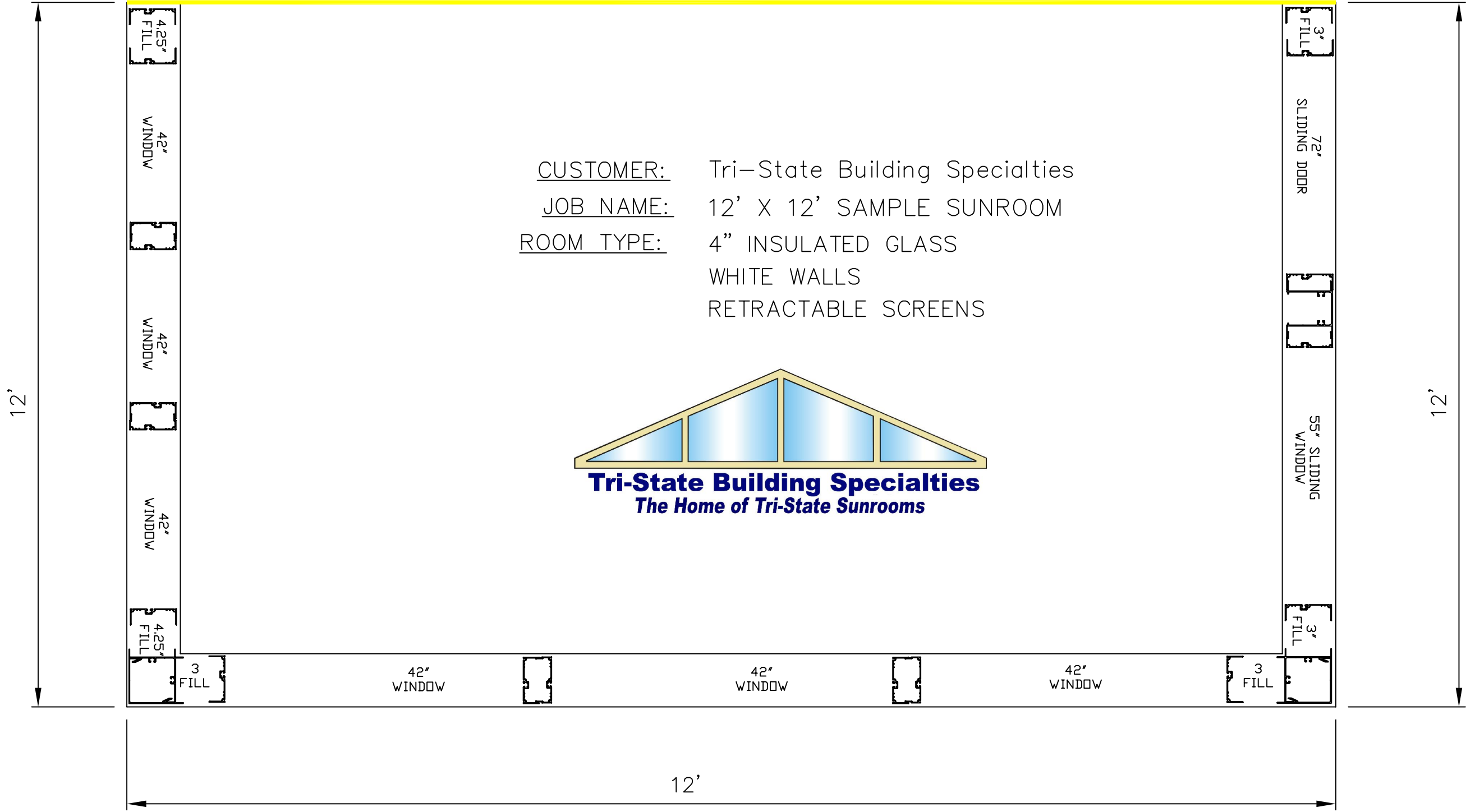

CUSTOMER: Tri-State Building Specialties
JOB NAME: 12' X 12' SAMPLE SUNROOM
ROOM TYPE: 4" INSULATED GLASS
 WHITE WALLS
 RETRACTABLE SCREENS

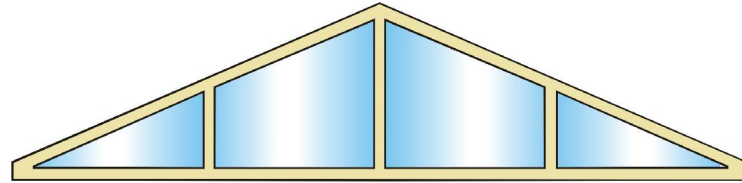

Tri-State Building Specialties
The Home of Tri-State Sunrooms

CLIENT: SAMPLE SUNROOM

TRI-STATE BUILDING SPECIALTIES
 1985 RUTGERS UNIVERSITY BLVD
 LAKEWOOD, NJ 08701



JAMES A. CLANCY

JAMES A. CLANCY

CONSULTING ENGINEER
 601 ASBURY AVENUE
 NATIONAL PARK, NJ 08063

Fax: 856-853-7381
 Phone 856-853-7306

Professional Engineer & Land Surveyor NJ LIC# 33998
 Professional Planner NJ LIC# 04200

FLOOR PLAN

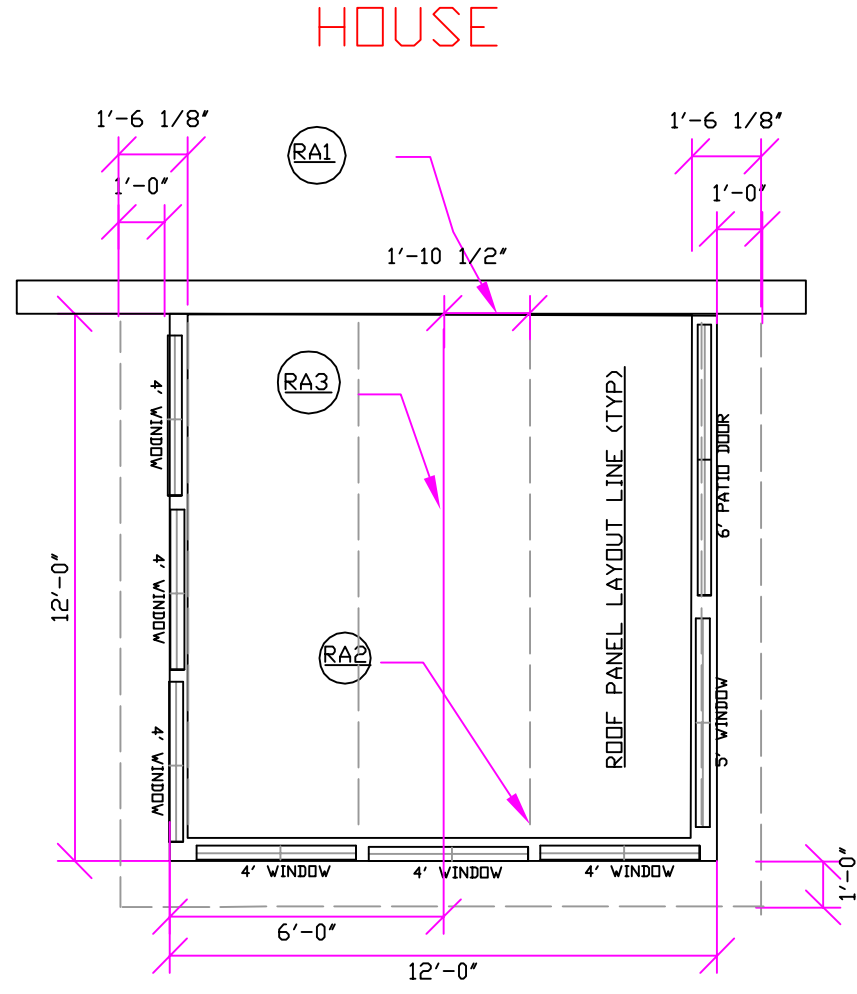

CLIENT: SAMPLE SUNROOM

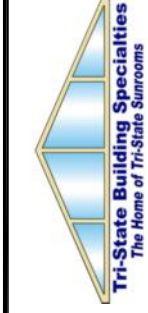

TRI-STATE BUILDING SPECIALTIES
1985 RUTGERS UNIVERSITY BLVD
LAKEWOOD, NJ 08701

JAMES A. CLANCY
CONSULTING ENGINEER
601 ASBURY AVENUE
NATIONAL PARK, NJ 08063

Fax: 856-853-7381
Phone: 856-853-7306

JAMES A. CLANCY

Professional Engineer & Land Surveyor NJ LIC# 33998
Professional Planner NJ LIC# 04200

CROSS SECTION

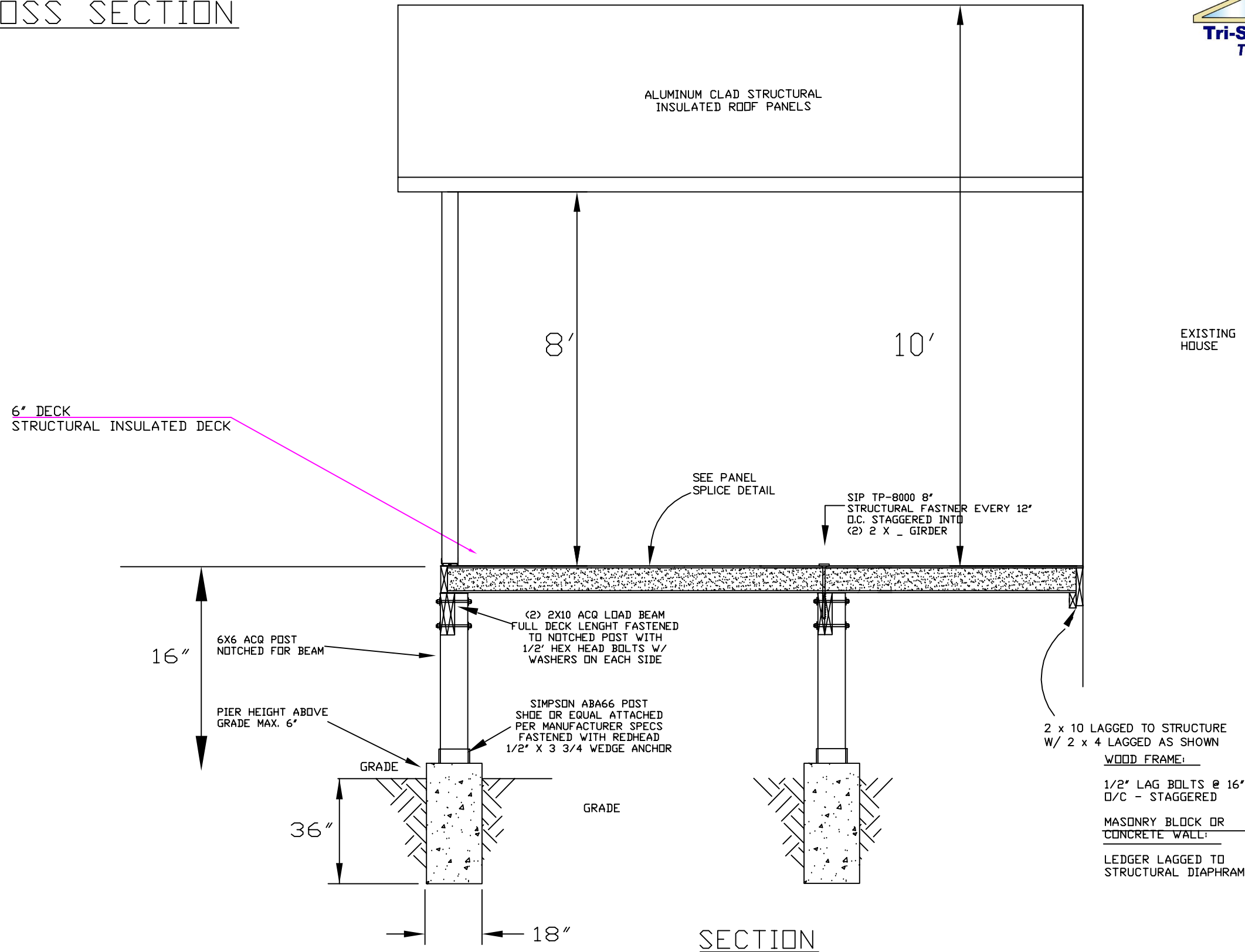

EXISTING HOUSE

SECTION

TRI-STATE BUILDING SPECIALTIES
 1985 RUTGERS UNIVERSITY BLVD
 LAKEWOOD, NJ 08701



CLIENT: SAMPLE SUNROOM

JAMES A. CLANCY

JAMES A. CLANCY
 CONSULTING ENGINEER
 601 ASBURY AVENUE
 NATIONAL PARK, NJ 08063

Fax: 856-853-7381
 Phone: 856-853-7306

Professional Engineer & Land Surveyor NJ LIC# 33998
 Professional Planner NJ LIC# 04200

ROOF CONNECTION DETAILS

#10 SMS AT 24" c/c MAXIMUM
BUT NOT LESS THAN 6-SCREWS PER
PANEL JOINT

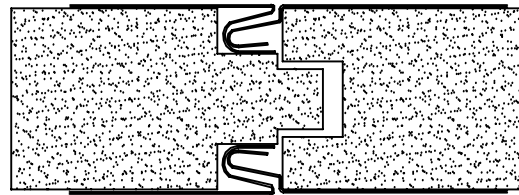
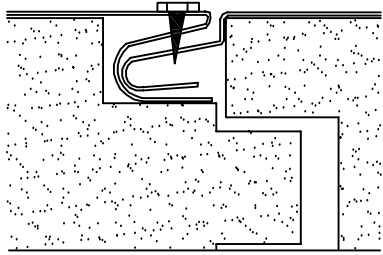

PANEL JOINT

RA2

Fascia

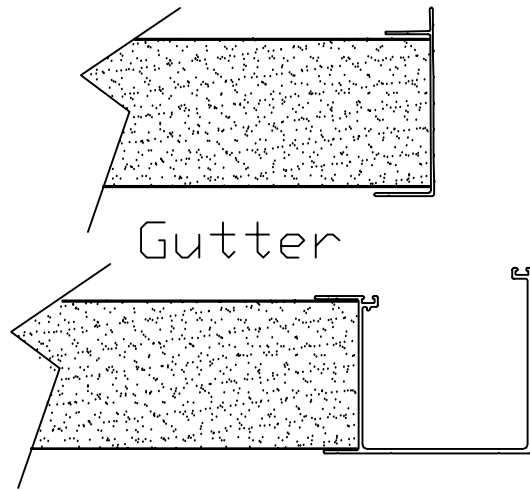

Gutter

RA1

ROOF CONNECTION RA1

METAL PREFLASH AND
CAULK TOP & BOTTOM
MOUNT W/ #8 x 1/2"
SCREWS @ 6" O.C.

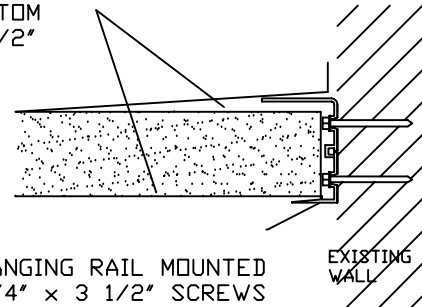

#12 HANGING RAIL MOUNTED
W/ 1/4" x 3 1/2" SCREWS
INTO EACH WALL STUD @16" O.C
STAGGERED TOP & BOTTOM

RA1-B

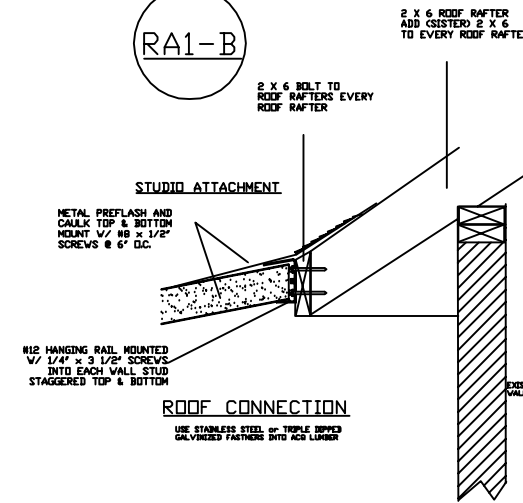

EXPANDED POLYSTYRENE CORE

3" - 4.25" - 6"

.032 INCH ALUMINUM

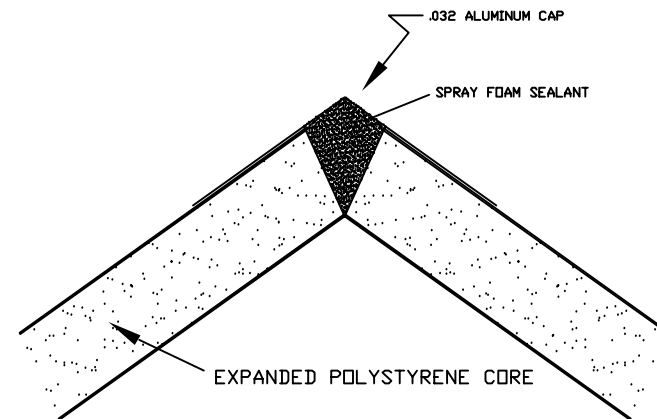
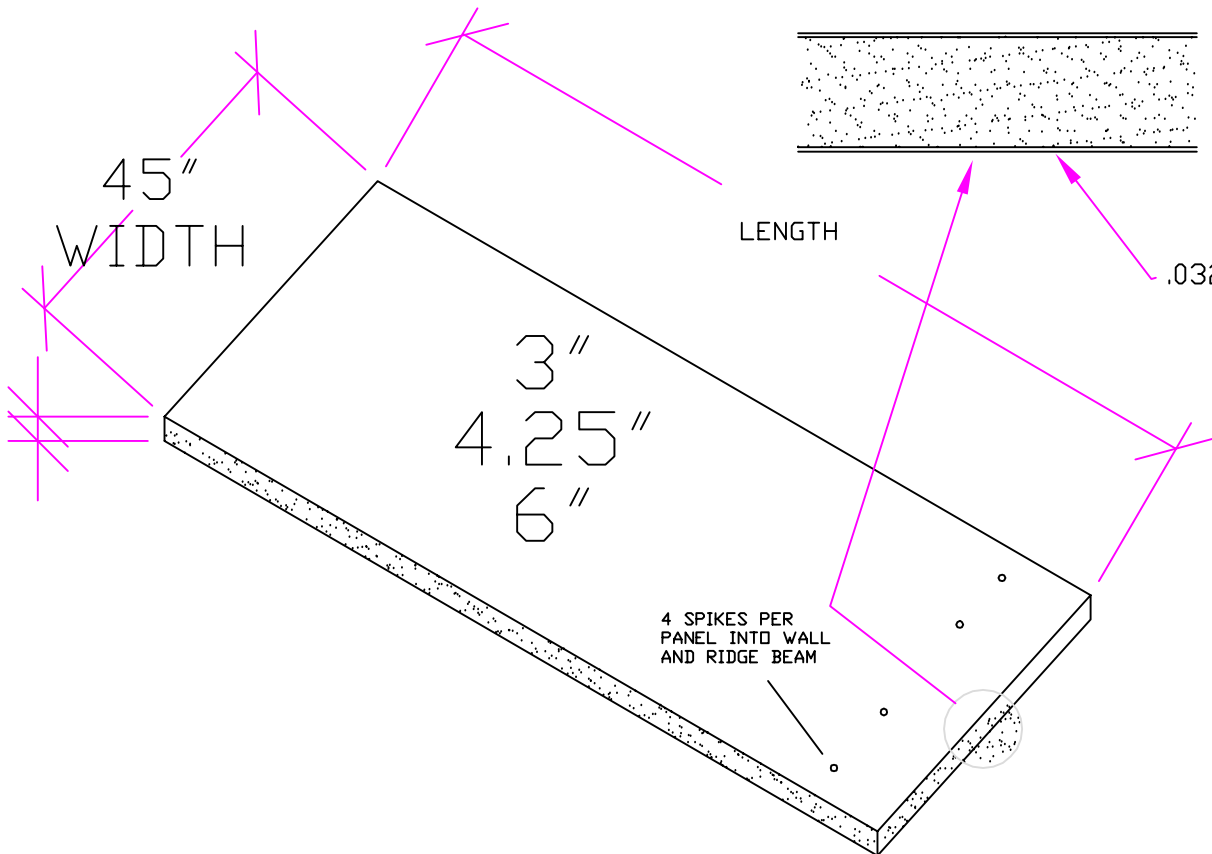

RA3

DETAIL
N.T.S.

RA4

RIDGE BEAM DETAILS

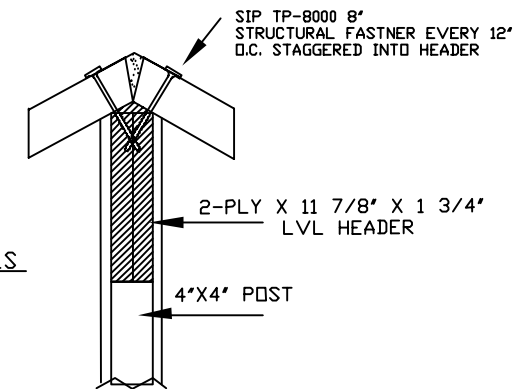

NOTE:
DUE TO VARYING CONSTRUCTION METHODS, THE RIDGE BEAM TO HOUSE
WALL CONNECTION IS THE RESPONSIBILITY OF THE CONTRACTOR.
CONTRACTOR RESPONSIBILITY TO MEET ALL BUILDING CODES

TRI-STATE BUILDING SPECIALTIES
1985 RUTGERS UNIVERSITY BLVD
LAKEWOOD, NJ 08701



CLIENT: SAMPLE SUNROOM

JAMES A. CLANCY

JAMES A. CLANCY
CONSULTING ENGINEER
601 ASBURY AVENUE
NATIONAL PARK, NJ 08063

Fax: 856-853-7381
Phone: 856-853-7306

NJ LIC# 33998
NJ LIC# 04200

Professional Engineer & Land Surveyor
Professional Planner

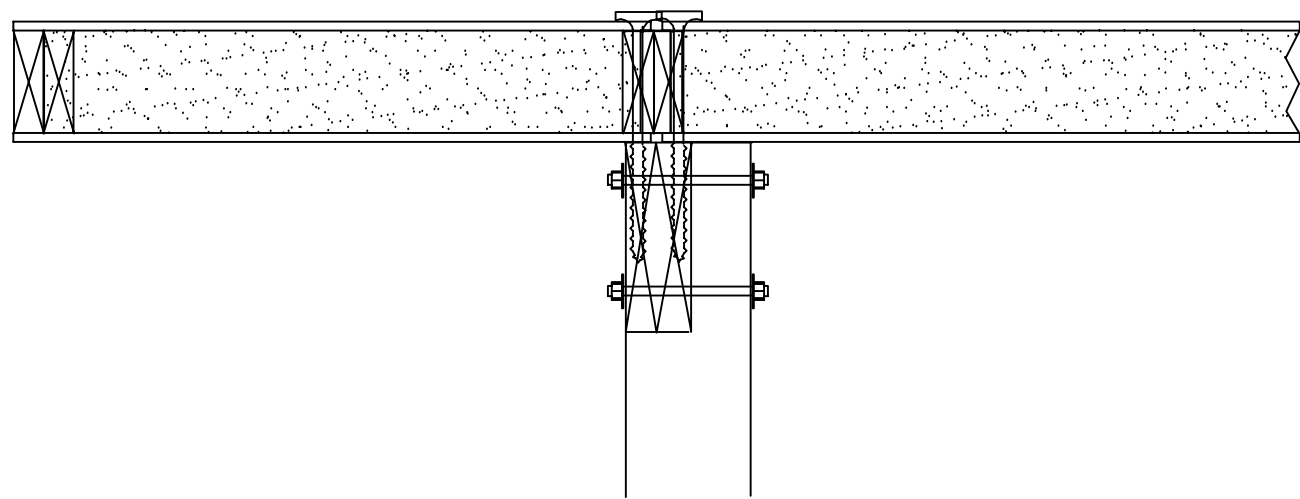

CROSS SECTION OF PANEL CONNECTION
END PANEL CONNECTION

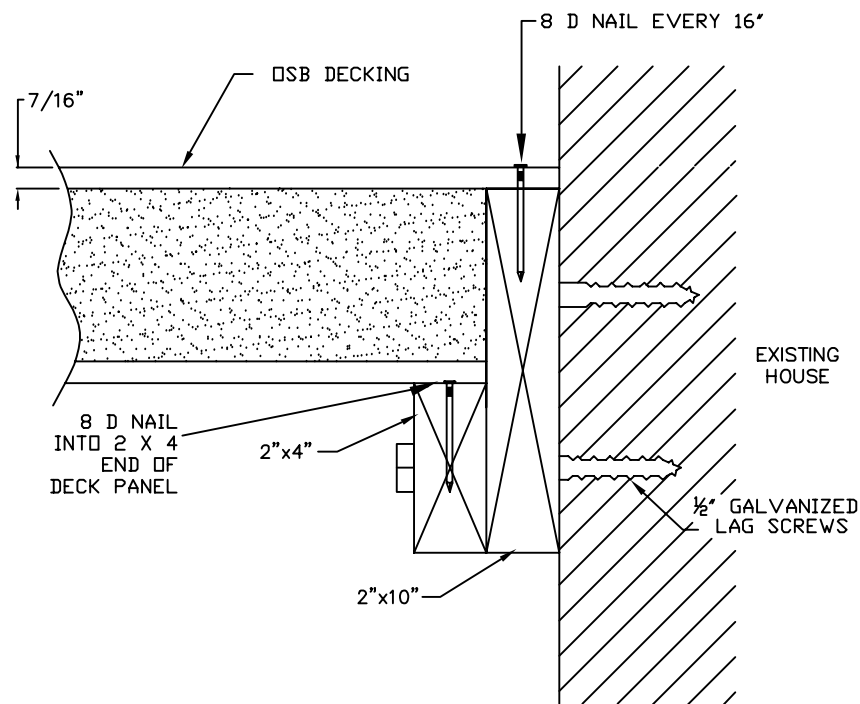

LEDGER DETAIL

EXTERIOR LUMBER ALL
PRESSURE TREATED

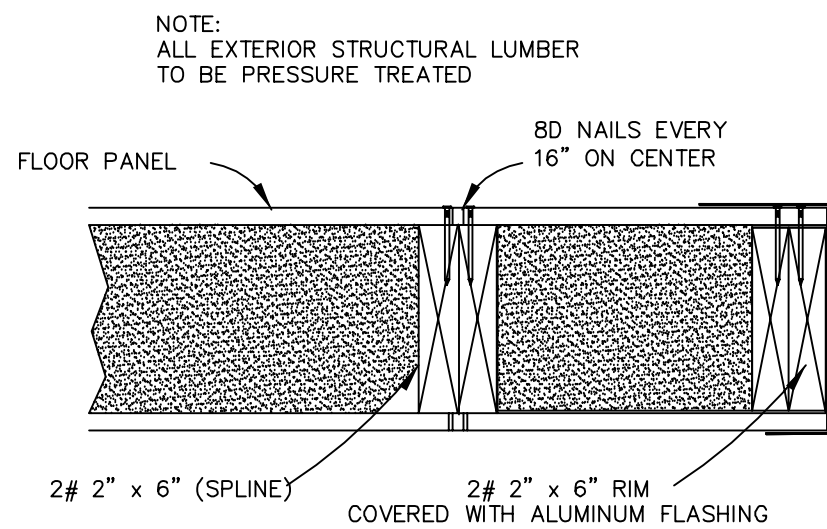

PANEL SPLICE DETAIL

NOTE:
ALL EXTERIOR STRUCTURAL LUMBER
TO BE PRESSURE TREATED

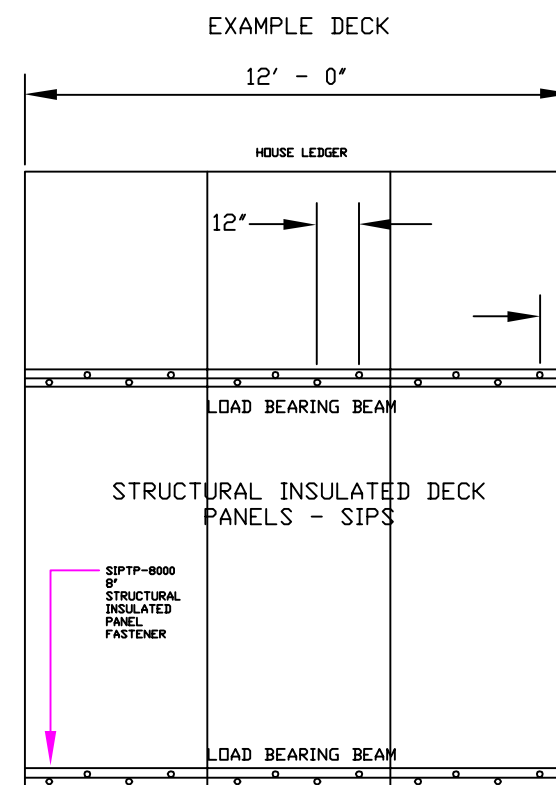

SCREW PATTERN DETAIL

TRI-STATE BUILDING SPECIALTIES
1985 RUTGERS UNIVERSITY BLVD
LAKEWOOD, NJ 08701

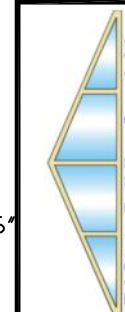

CLIENT: SAMPLE SUNROOM

JAMES A. CLANCY

JAMES A. CLANCY

CONSULTING ENGINEER
601 ASBURY AVENUE
NATIONAL PARK, NJ 08063

Fax: 856-853-7381
Phone: 856-853-7306

Professional Engineer & Land Surveyor NJ LIC# 33998
Professional Planner NJ LIC# 04200